

Matrix Converter fed Three-Phase Induction Motor with Closed Loop Speed Control

Ms. D Saiprasanthi, Assistant Professor, EEE Department, Ramachandra College of Engineering, Eluru

Mrs. B. Patrisamma, Assistant Professor, EEE Department, Ramachandra College of Engineering, Eluru

Mr. Ch S K B Pradeep Kumar, Assistant Professor, EEE Department, Ramachandra College of Engineering, Eluru

Mrs. Ch. Sabitha, Assistant Professor, EEE Department, Ramachandra College of Engineering, Eluru

Ms. Ch K T S R Kowstubha, Assistant Professor, EEE Department, Ramachandra College of Engineering, Eluru

Abstract- Matrix converters (MC) are compact voltage source converters capable of providing variable voltage and variable frequency at the output. Compared with traditional topologies the MC does not require an intermediate DC link and provides sinusoidal output waveform with minimum higher order harmonics. Various applications in the modern world require DC supply, the presented paper deals with the designed concept of the matrix converter control system with Sinusoidal Pulse Width Modulation (SPWM) technique employed in the industry applications. Matrix converters provide an all-silicon solution to the problem of converting AC power from one frequency to another, offering almost all the features required of an ideal static frequency changer. In this method the Safe commutation strategy was implemented to solve switching transients. The main goal is to reduce the cost and to improve the reliability of drive systems that involve closed-loop control strategy. When compare to delay angle control method, the SPWM method is better, because by use of SPWM we can reduce the harmonic content and increase the efficiency. This paper is subjected to passive load conditions. The results are obtained through Matlab/Simulink software package.

Keywords- Sinusoidal Pulse Width Modulation (SPWM), Insulated Gate Bipolar Transistor (IGBT), Single-Phase Matrix Converter (SPMC), Three-Phase Matrix Converter (TPMC), Frequency Changer.

INTRODUCTION

A MATRIX CONVERTER (MC) consists of an array of bidirectional switches, which are used to directly connect the power supply to the load without using any dc-link or large energy storage elements [1]. The most important characteristics of MCs are as follows [2], [3]: 1) a simple and compact power circuit; 2) generation of load voltage with arbitrary amplitude and frequency; 3) sinusoidal input and output currents; 4) operation with unity power factor; and 5) regeneration capability. These highly attractive characteristics are the reason for the tremendous interest in this topology.

The most popularly widely used motor in motion industries is the AC induction motor as they are robust, reliable, simple, cheap and available in all power ratings. The squirrel cage type of induction motor is very popular in case of variable-speed drives. When AC power is provided to an induction motor, it runs at its rated speed. However, many applications need variable speed operations particularly in industries. Induction Motors have been widely used mainly for constant-speed applications. Matrix converter fed motor drive is superior to pulse width modulation (PWM) inverter drives because it provides bidirectional power flow, sinusoidal input/output currents, and

adjustable input power factor [1], [2]. Furthermore, matrix converter allows a compact design due to the lack of dc-link capacitors for energy storage. However, only a few of practical matrix converters have been applied to vector control system of induction motors (IM) for the reason: Modulation technique and commutation control are more complicated than conventional PWM inverter [2].

The intensive research on MCs starts with the work of Venturini and Alesina in 1980 [2]. They provided the rigorous mathematical background and introduced the name "matrix converter," elegantly describing how the low - frequency behaviors of the voltages and currents are generated at the load and the input. One of the biggest difficulties in the operation of this converter was the commutation of the bidirectional switches [4]. This problem has been solved by introducing intelligent and soft commutation techniques, giving new momentum to research in this area.

In this work a simple commutation strategy for implementation in SINGLE PHASE MATRIX CONVERTER provides the required free-wheeling operation similar to those available in other converter topologies is proposed. The aim of this paper is to describe work involved in modeling and simulation on the implementation of the Single- Phase Matrix Converter (SPMC) as an AC-AC converter subjected to passive load conditions. The output voltage was synthesized using the well-known Sinusoidal Pulse Width Modulation (SPWM) as suggested by Firdaus with the IGBT as the power switching devices. Safe-commutation strategy was implemented to solve switching transients. The MATLAB/Simulink (MLS) with the Sim Power System (SPS) Block Set are used in this instance providing a flexible and versatile simulation environment.

THE SPMC

Typically, a matrix converter or "forced commutated cycloconverters" Conceptually, the switches are arranged in two groups Generally, the matrix converter provides unrestricted frequency conversion, high quality input and output wave forms, and unity input displacement factor. It has the inherent capability to regenerate from a load to the mains supply and is particularly attractive because it does not require bulk energy storage components. In principle, a matrix converter switching at a high frequency can have a smaller physical size than other power converter types with current matrix converter circuits.

Safe-commutation strategy was implemented to solve switching transients, theoretically the switching in the SPMC must be instantaneous & simultaneous; Unfortunately it is impossible for realizing in practical systems due to the IGBT turn- off characteristic. Where the tailing-off of the collector current will create a short circuit with next switching turn-on, this problem occurs when inductive loads are used. The MATLAB/Simulink (MLS) with the SimPowerSystem (SPS) Block Set are used in this instance providing a flexible and versatile simulation environment.

Model Diagram of SPMC

The Matrix Converter is a forced commutated AC- AC Converter, which uses an array of controlled 4 bi-directional IGBT switches as the main power elements to create a variable output voltage system with unrestricted frequency. We are already discussing about the IGBTs in chapter [3], each capable of conducting current in both directions, blocking forward & reverse voltages. The SPMC is subjected only passive (i.e., R, R-L) load conditions.

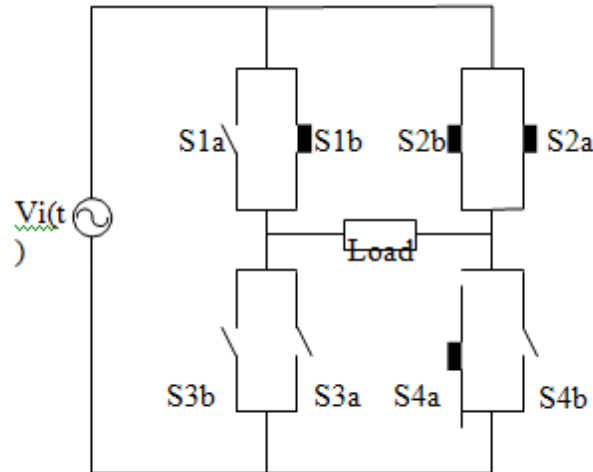

Fig. 1: SPMC

SPMC topology is restricted due to inherent limitations. One of those limitations is the absence of the natural freewheeling path. In this work a simple Commutation strategy for implementation in SPMC provides the required freewheeling path & solves the switching transients.

Here from fig: 4.1, the input and output voltage of the SPMC is given by (1) and (2) respectively with loads in (3);

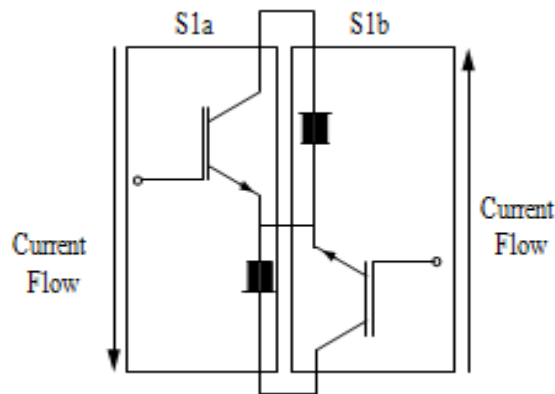

Fig 2: Bidirectional switch module (common emitter) III. SINUSOIDAL PULSE WIDTH MODULATION (SPWM)

The Sinusoidal Pulse Width Modulation (SPWM) is a well known wave shaping technique in power electronics as illustrated in Fig. 3. For realisation, a high frequency triangular carrier signal, V_c , is compared with a sinusoidal reference signal, V_{ref} , of the desired frequency. The crossover points are used to determine the switching instants.

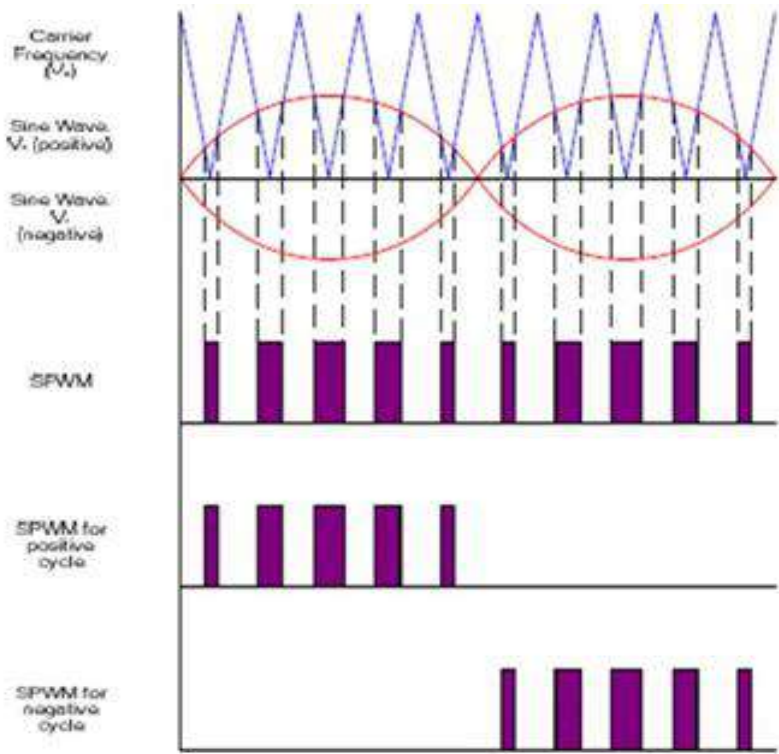

Fig. 3: Formation of SPWM

$$V_I(t) = \sqrt{2} V_I \sin \omega t \dots\dots\dots (1)$$

$$V_O(t) = \sqrt{2} V_O \sin \omega_o t \dots\dots\dots (2)$$

$$V_O(t) = R i_o(t) + L di_o(t) / dt \dots\dots\dots (3)$$

The magnitude ratio of the reference signal (V_{ref}) to that of the triangular signal (V_a) is known as the modulation index (m_i). The magnitude of fundamental component of output voltage is proportional to m_i . The amplitude V , of the triangular signal is generally kept constant. By varying the modulation index, the output voltage could be controlled.

SWITCHING STRATEGIES

Here the fig: 4 show SPMC for 100Hz operation at fundamental frequency is 50Hz. At any time,,t “, any two switches S_{ij} below will be ON;

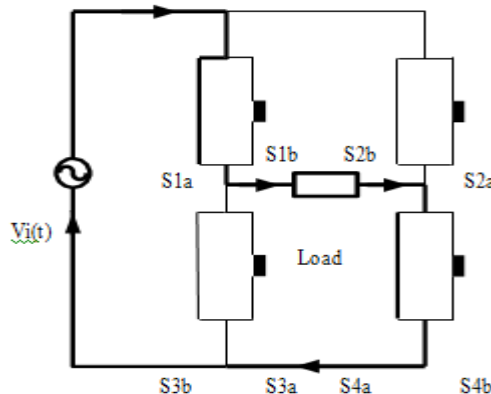

Fig. 4: State 1 positive cycle

Here in fig: 5 ($i = 1, 4$ and $j = a$) will conduct the current flow during positive cycle of input source.

(State 1), with S2a turn „ON“ for commutation purpose.

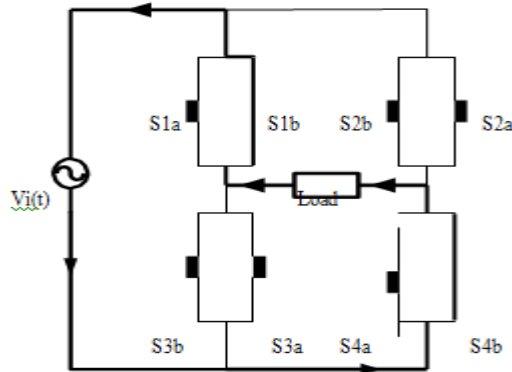

Fig. 5: State 2 negative cycle

Here in fig: 6 ($i = 1, 4$ and $j = b$) will conduct the current flow during negative cycle of input source. (State 2), with S2b turn 'ON' for commutation purpose.

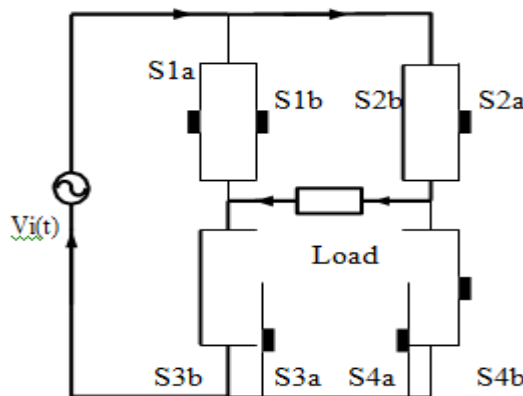

Fig. 6: State 3 positive cycle

Here in fig: 7 ($i = 2, 3$ and $j = b$) will conduct the current flow during positive cycle of input source. (State 3), with S1b turn „ON“ for commutation purpose.

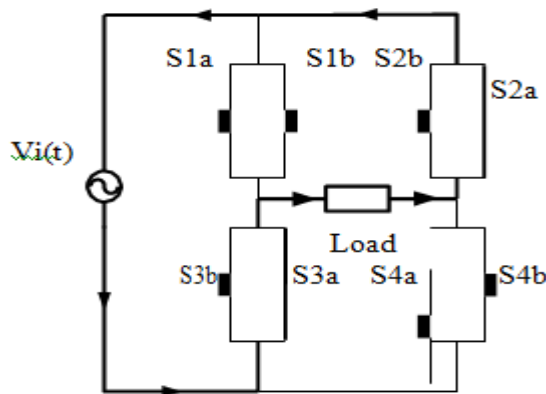

Fig. 7: State 4 negative cycle

Here in fig:7 ($i = 2, 3$ and $j = a$) will conduct the current flow during negative cycle of input source.

(State 4), with S1a turn „ON“ for commutation purpose.

The output frequency is synthesized in multiples of 50Hz input frequency (say 50Hz, 100Hz and 150Hz) and the operations are illustrated as in Figures above. The sequences of switching are dependent on the time interval and state of the driver circuit, represented by table 1 (For one cycle).

COMMUTATION STRATAGEY

The commutation method herein permits two switch circuits within the same switching group to be enabled simultaneously without shorting the AC mains associated with the individual switch circuits. The method may require the continuous determination of the desired polarity of the current the individual switch circuits. The method may require the continuous determination of the desired polarity of the current particular time. Once the proper polarity is selected, the individual switching circuits within each switching group can be enabled to permit current flow of the desired polarity and block current of With the switch circuits of a switching group thus enabled, a second switch circuit within a group may be enabled while a first switch circuit within the same switching group is still energized with the load current. This method permits natural commutation from the first switch circuit to the second switch circuit to occur whenever possible during the overlapping period of first switch circuit and second switch circuit enabling. If natural commutation does not occur, or is incomplete, the first switch circuit is disabled, forced commutation is effected, and the second switch circuit conducts the full load current.

If a change in current polarity is indicated, then all switch circuits within a switching group may be momentarily disabled to prevent shorting of the AC mains associated with the individual switching circuits. One apparatus which embodies the commutation method herein includes polarity- sensitive switching devices that can be controlled by a matrix converter controller. Each of these switching devices can provide unidirectional current control and flow in either of two directions, respective of the desired current polarity, while blocking the flow of current in the opposite direction. In one presently preferred embodiment of the present invention, the switching devices can be controlled by a gating control means that determines which power switch is enabled to conduct current and which Polarity of current flow is enabled. Accordingly, the matrix converter controller can act in concert with the gating control means to provide desired enabling presently preferred embodiment, a gating control means can use input data such as a group current reference signal and group switch selection data to determine the desired polarity of the load current through the switches and to transmit the desired state of the switches within a group to the switch conduction enable circuit. The polarity-controlled, bi- directional switch permits particular switches operable on a particular line phase to be enabled at reselected times and regulates the initiation and duration of the switch gating overlap period, as well as current flow. The switch gating control circuit can receive reference signals from the matrix converter controller, as well as from the supply, to facilitate the selection of the preferred polarity for the switches in a switch group. In addition, whenever the switch gating control circuit senses that a change in polarity selection is indicated, a brief underlap period may be imposed upon all switches in the group, during which no switches are enabled for conduction in any direction.

Fundamental input waveform

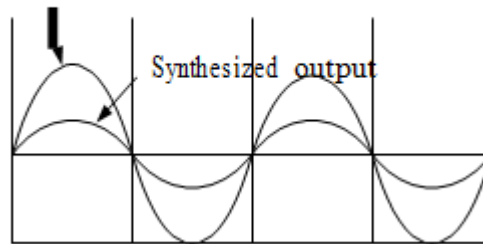

Fundamental input waveform Inverted waveform

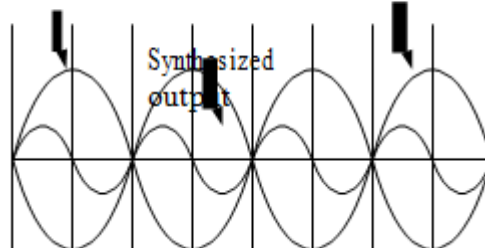

Fundamental input waveform Inverted waveform

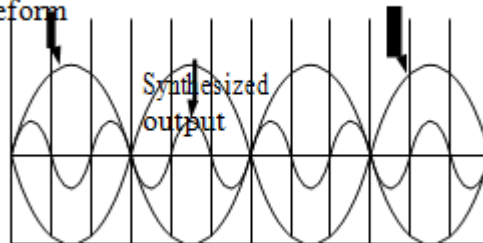

Fig. 8: Sinusoidal and Synthesized output (a) 50 Hz (b) 100Hz reference (c) 150 Hz

The following table 1 gives the sequence of switching of the IGBT switches for different output frequencies. The sequences of switching are dependent on time interval and state.

TABLE 1: SEQUENCE OF SWITCHING CONTROL

Input Frequency	Output Frequency	Time Interval	State	PWM Switch	Commutation Switch
50Hz	50 Hz	1	1	S4a	S1a & S2a
		2	2	S4b	S1b & S2b
	100 Hz	1	1	S4a	S1a & S2a
		2	3	S3b	S2b & S1b
		3	4	S3a	S2a & S1a
		4	2	S4b	S1b & S2b
		1	1	S4a	S1a & S2a
		2	3	S3b	S2b & S1b
		3	1	S4a	S1a & S2a
		4	2	S4b	S1b & S2b
		5	4	S3a	S2a & S1a
		6	2	S4b	S1b & S2b

Let's say the output frequency is 50 Hz. To achieve this, when the supply voltage is positive the switch is set to state 1 (S1a and S4a are turned ON). On the other hand switching state 2 are used during negative cycle to produce the next half cycle. For other output frequencies, the sequence of switching is similar to the 50 Hz output frequency as listed in table 1 with a total of four (4) different switching states, capable of being used in various combinations to produce the desired effect.

THE TPMC

The three-phase matrix converter (TPMC) concept, introduced by Venturini and Alessina in 1979, seems to be the most advanced concept for static energy conversion. The TPMC, which is mainly a three-phase AC/A,C direct converter (without DC link) is also capable of rectifying [4] and inverting [5]. The theoretical characteristics of the circuit are satisfactory output current waveforms, bidirectional energy flow, minimal energy storage passive elements and adjustable input power factor. All published studies dealt with three- phase circuit topologies, their control [6, 7] and power switch protection. The closed loop control of three phase induction motor using PI controller was also simulated.

MAIN SIMULATION

Computer simulation offers the opportunity to experiment with phenomena or events, which for a number of reasons, cannot normally be experimented with in the traditional way. Computer simulation programs can be used in education to give the student more feeling for reality in some abstract fields of learning. Digital simulation tool like MATLAB is an essential tool for all simulation studies of various systems of engineering disciplines. It is a scientific tool having wide applications in Digital Signal Processing, Adaptive Signal Processing, Digital Communication, Intelligent Instrumentation, Soft Computing (ANN, FL and GA), and Statistics, Digital Filter Design, Control System, Curve Fitting and several others. Here, in this paper The MATLAB/Simulink (MLS) with the Sim Power System (SPS) Block Set are used in this instance providing a flexible and versatile simulation environment.

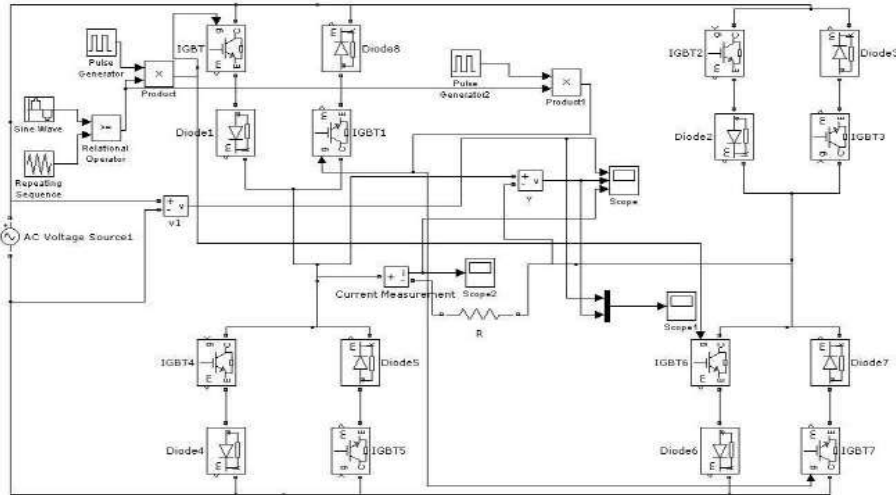

Fig. 9: Simulation circuit of 50Hz matrix converter

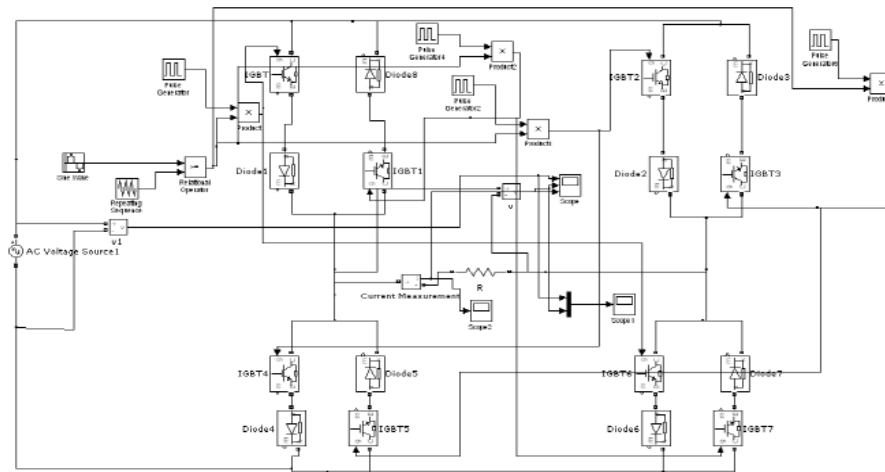

Fig. 10: Simulation circuit of 100Hz matrix converter

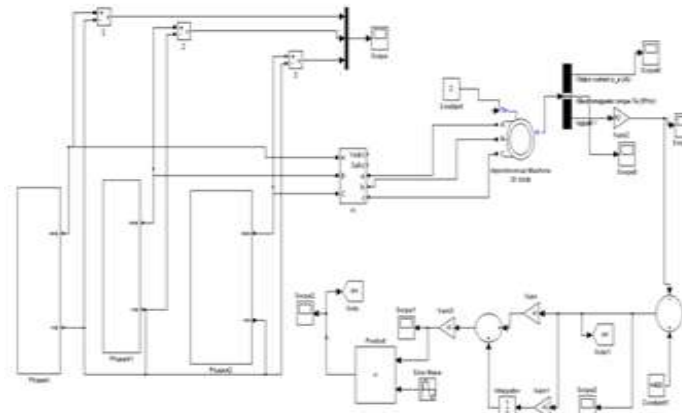

Fig. 11: Simulink model of the three phase closed loop matrix converter

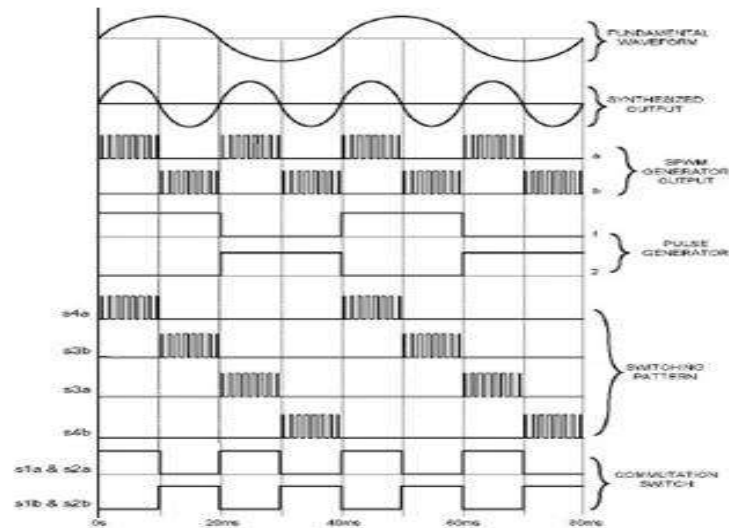

Fig. 12: Switching Pattern Generator (100 Hz)

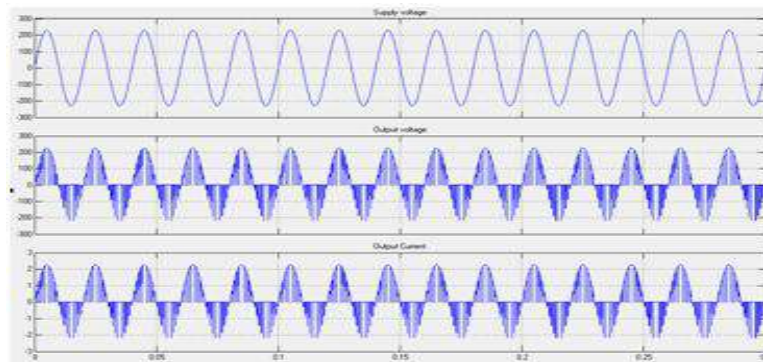

Fig. 13: MLS Simulation of SPMC with $f_r=50$ hz supply voltage, O/P Voltage, O/P Current

RESULTS

Simulation results are presented in the following figures.

TABLE 2: SYSTEM PARAMETERS

Input Source (AC)	230V
Reference Frequency Signal (f_r)	50Hz, 100Hz & 150Hz
Carrier Signal (f_c) & Load	1KHz, R=50Ω
Sample Modulation Index m_i	0.5 & 1.0

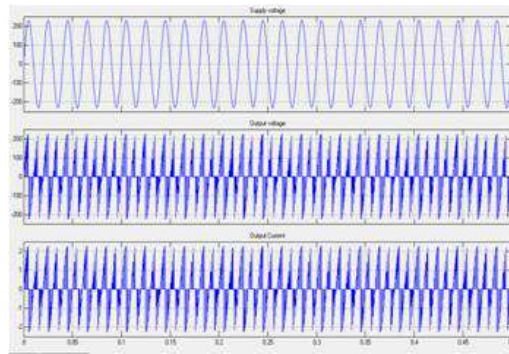

Fig. 14: MLS Simulation of SPMC with $f_r=100$ hz supply voltage, O/P Voltage, O/P Current

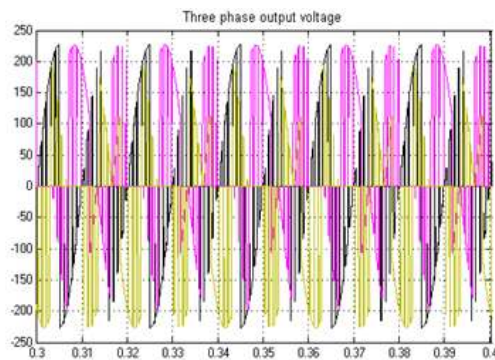

Fig. 15: Three phase output voltage waveforms

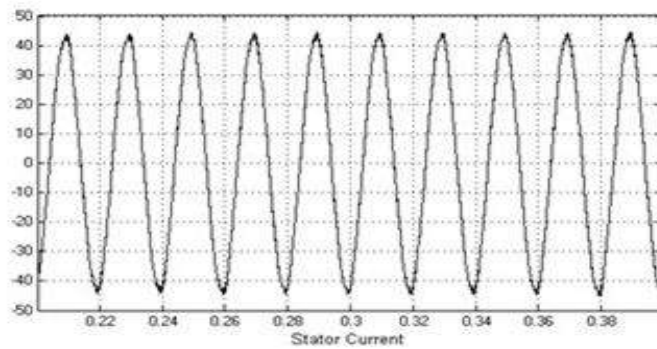

Fig. 16: Stator current of the induction motor

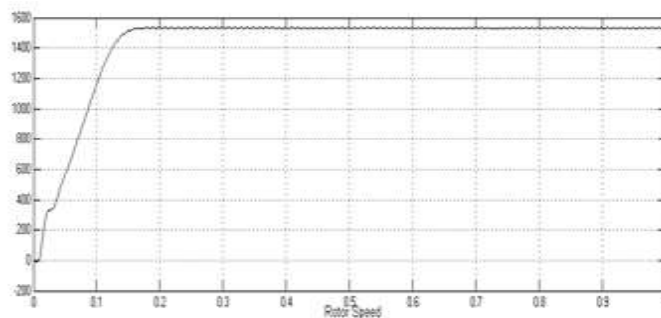

Fig. 17: Rotor Speed of the induction motor

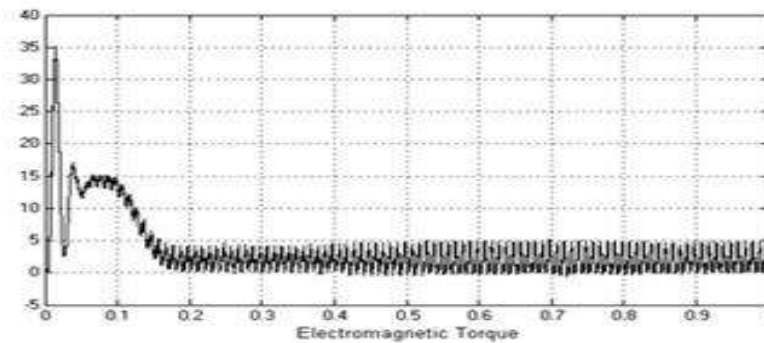

Fig. 18: Electromagnetic torque of the motor

CONCLUSION

In this paper the modelling and simulation of the Single- Phase Matrix Converter (SPMC) as an AC-AC converter with passive load conditions had been presented. The output voltage was synthesized using the well-known Sinusoidal Pulse Width Modulation (SPWM) with the IGBT as power switching devices. Safe-commutation strategy was implemented to solve switching transients. The MATLAB/Simulink (MLS) with the SimPowerSystem (SPS) Block Set are used in this instance providing a flexible and versatile simulation environment. Three phase matrix converter was also simulated and given to the input of three phase induction motor and control the speed of the induction motor using the PI controller.

REFERENCES

- [1] H. Mohd Hanafi, Z. Idris, M. K. Hamzah, Member, IEEE and Azilah Saparon, "Modelling & Simulation of Single-phase Matrix Converter as a Frequency Changer with Sinusoidal Pulse Width Modulation Using MATLAB/Simulink".
- [2] Zuucerberger, A., Weinstock, D., Alexandrovitz A., "Single-Phase Matrix Converter" IEE Proc. Electric Power App, Vol.144(4), Jul 1997 pp.235-240.
- [3] Hosseini, S.H.; Babaei, "A New Generalized Direct Matrix Converter" Industrail Electronics, 2001. Proc. ISIE 2001. Vol(2) , 2001 pp1071-1076.
- [4] Abdollah Koei & Subbaraya Yuvarajan, "Single -Phase AC-AC Converter Using Power Mossfet's ," IEEE Transaction on Industrial Electronics, Vol. 35, No.3, august 1988 pp442-443.
- [5] Firdus, S., Hamzah , M.K., "Modeling & Simulation of a single - phase AC-AC Matrix Converter using SPWM," Research & Development, 2002.
- [6] Zahiruddin Idris, Siti Zaliha Noor & Mustafar Kamal Hamzah "Safe Commu tation Strategy in Single-Phase Matrix converter," IEEE Sixth International Conference PEDS 2005, Kulal Lumpur Malaysia.
- [7] Cho, J.G., and Cho, G.H, "Soft-switched Matrix Converter for High Frequency direct AC-to-AC Power Conversion," Int. J. Electron., 1992, 72, (4), pp. 669-680.
- [8] Wheeler, P.W., Clare, J.C., Empringham, L., Bland, M., Kerris, K.G., "Matrix converters," Industry Applications Magazine, IEEE Volume: 10, Issue:1, Jan-Feb2004 Pages:59 - 65.
- [9] Abdollah Koei & Subbaraya Yuvarajan, "Single-Phase AC-AC Converter Using Power Masfet' s," IEEE Transaction on Industrial Electronics, Vol. 35, No.3, August 1988 pp442-443.
- [10] Gyugyi,L & Pelly,B.R, "Static Power Chargers, Theory, Performance and Application," John Wiley & Son Inc, 1976.